

Math 113 Third Exam
Version B

June 11, 2004
11:30am - 12:20pm
Márton Balázs

NAME:

Keep exact values whenever possible.
Full credit can only be given to justified answers.

1. (25 points) Write 255° as half angle, and use the half angle identities to determine the **exact** values of $\sin(255^\circ)$, $\cos(255^\circ)$, and then $\tan(255^\circ)$, $\cot(255^\circ)$.

2. We are 120 ft above the ground, at the rightmost point of a ferris wheel of diameter 240 ft.
- (a) (10 points) Determine **all** angles of rotation of the wheel, compared to this position, where our altitude will be 200 ft above the ground.
 - (b) (15 points) Determine **all** angles of rotation of the wheel, compared to the case when our cabin is at the rightmost position, where our **horizontal** distance from the center of the wheel is 70 ft.

3. (25 points) The shaded area on the right hand-side is a plateau, beginning with a 800 ft long side which has an angle of elevation of 30° . As this is way too steep for trains, a viaduct ascending at an angle of 1.5° is needed. Use Law of Sines or Law of Cosines to compute the length of the viaduct, and the distance between the bottom of the side of the plateau and the point to the left where the viaduct begins. Express these distances in miles also (1 mile = 5280 ft).

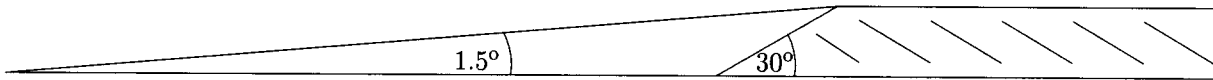

Bonus question (10 points, only try when all other problems are completed and verified): Find the maximum height of the viaduct, i.e. the maximal height of a point of the viaduct above the ground surface.

4. (25 points) A 120 ft high crane is lifting a car of 2400 pounds just a little bit above the ground. A worker pulls the car horizontally, with a force of 70 pounds, and so the car is at rest. Compute the angle α and the horizontal distance the worker was able to move that car.

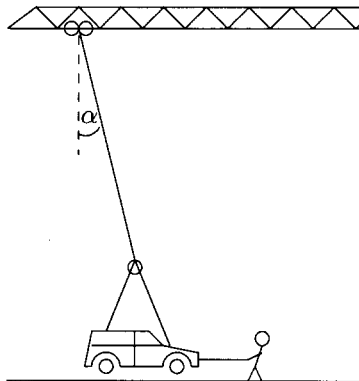

5. (20 points) Compute $(-1 - \sqrt{3}i)^3$. Give the answer in rectangular form.